

SHOWCASE SERIES

EXHIBITION KITS (SC-EXB-2D-BLK/SC-EXB-3D-BLK)



FEATURES

- + The Showcase Series is the most versatile wine rack system we have released yet by offering label-out, neck out, angled, and shelf presentation options.
- + High-quality materials make for sturdy construction and simple assembly.
- + Telescoping posts designed for ceilings up to 10 ft
- + Modern industrial matte black finish
- + CAD blocks available

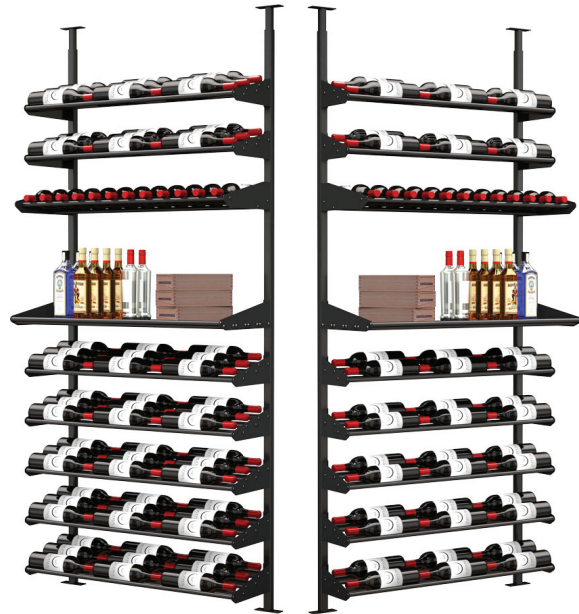

Featured Showcase Exhibition 2D Kit

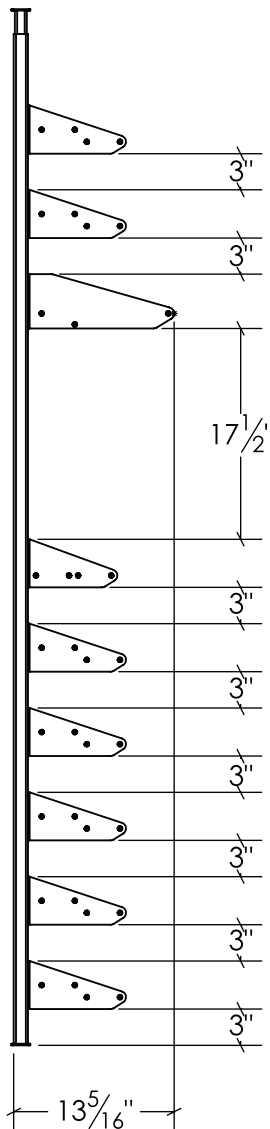

Featured Showcase Exhibition 3D Kit

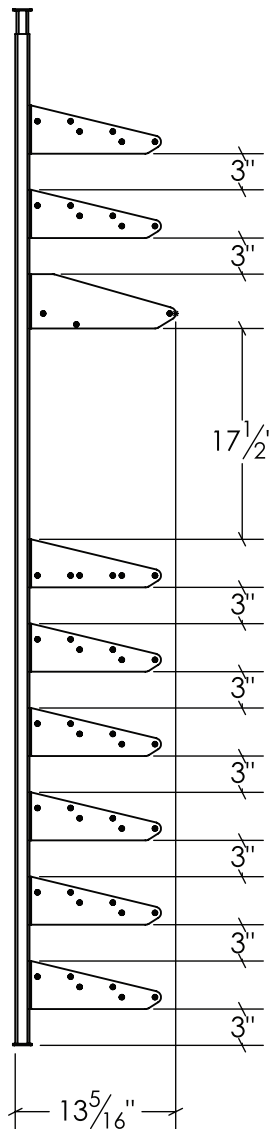

***Continue to the next page for more detailed specs on the 2 deep & 3 deep variations.**

SHOWCASE SERIES

EXHIBITION KITS (SC-EXB-2D-BLK)



Featured Showcase Exhibition 2D Kit

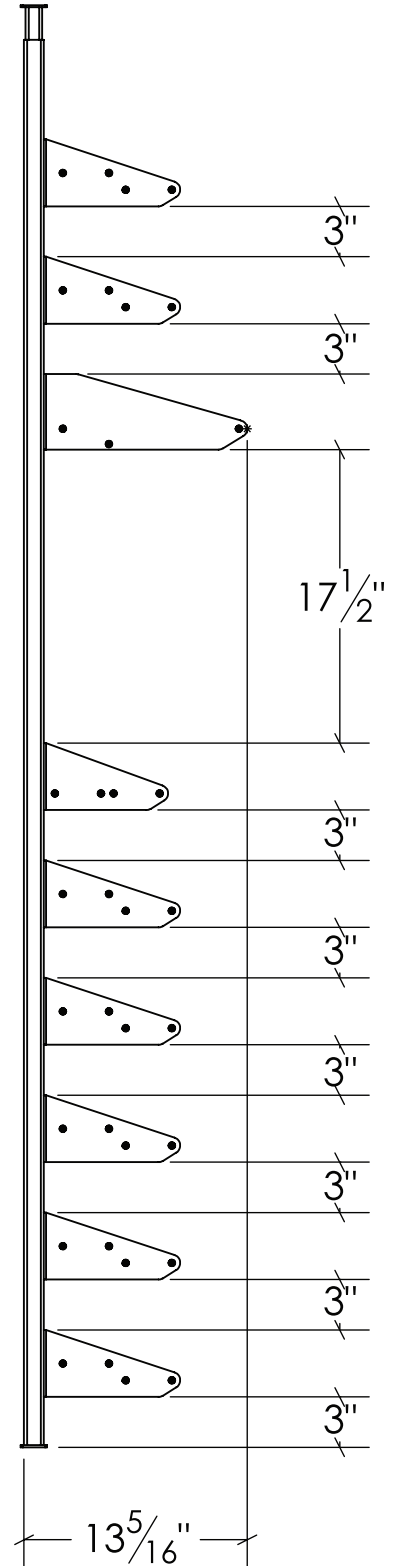
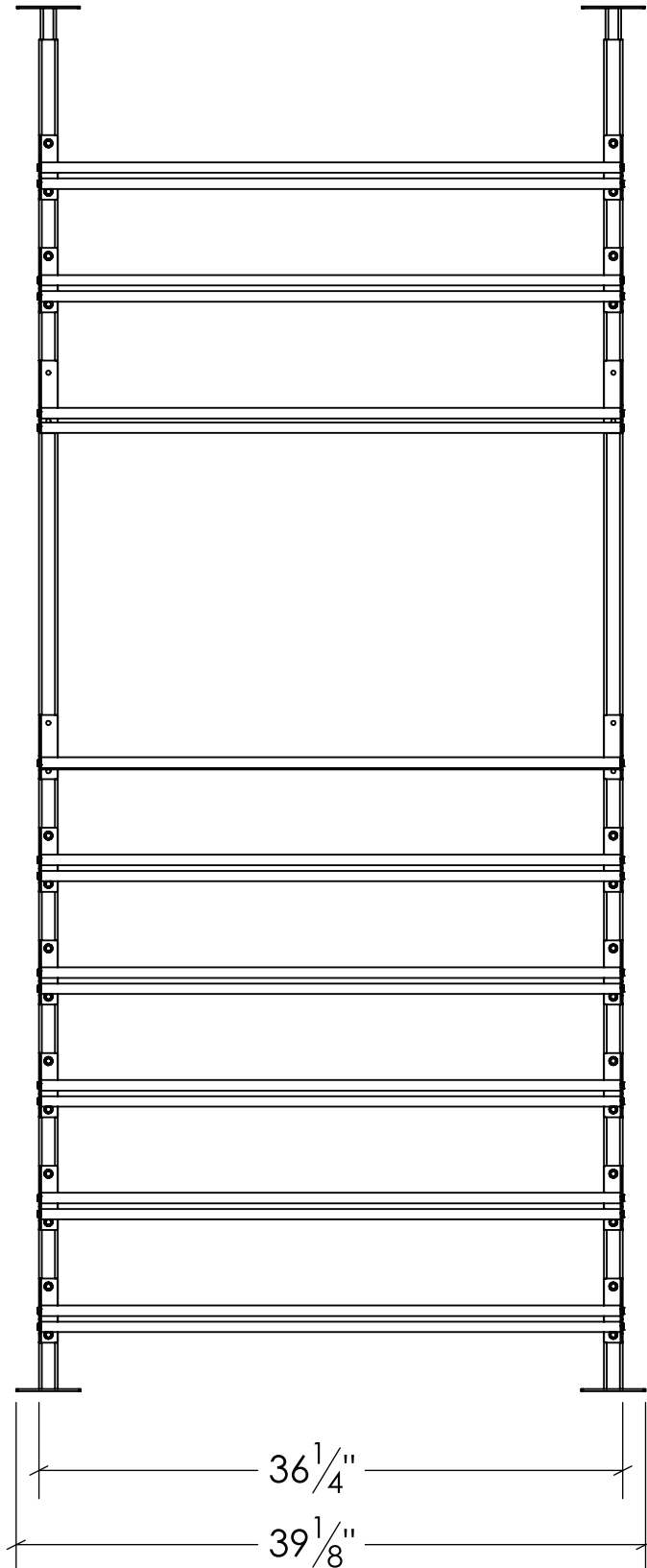

SHOWCASE SERIES

EXHIBITION KITS (SC-EXB-3D-BLK)



Featured Showcase Exhibition 3D Kit

