

ELITE KIT RACK ASSEMBLY INSTRUCTION

Thank you for purchasing Elite Kit Rack by Genuwine Cellars. The following instructions will help you assemble the 750ml CURVED CORNER. Assemble will be broken down into three sections.

Please study the instructions carefully prior to starting the assembly.

750ml CURVED CORNER Section 3 Complete

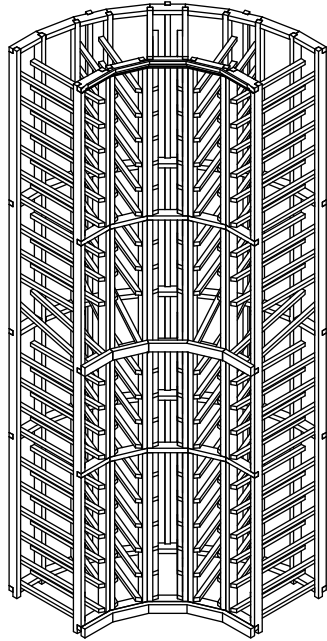

Section 1
Left & Right

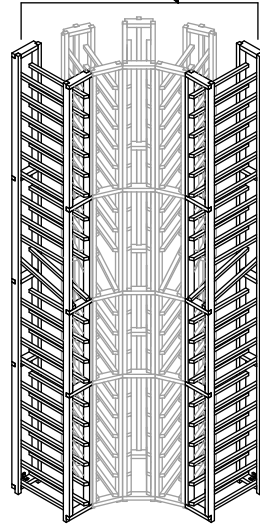

Section 2
Middles

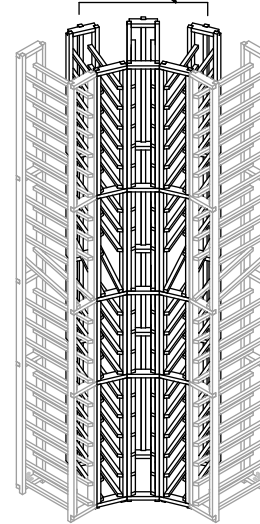

HARDWARE

The following hardware is included in all kits:
(QUANTITY WILL VARY, DEPENDING ON KIT.)

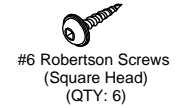
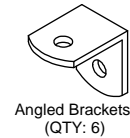
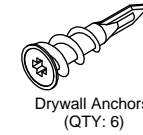

TOOLS REQUIRED

The following tools are required (NOT INCLUDED):

IMPORTANT!

Always follow the manufacturer's instructions on how to use the nail gun, to prevent injury. Genuwine Cellars is not liable for any injury incurred while assembling the kit.

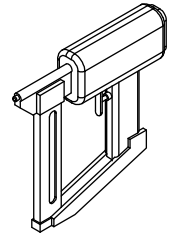
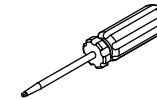

COMPONENTS

The following components are included in the 750ml CURVED CORNER.

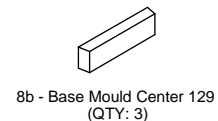
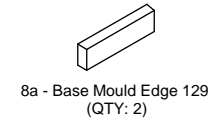
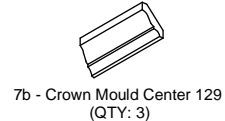
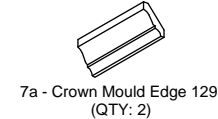
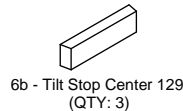
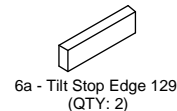
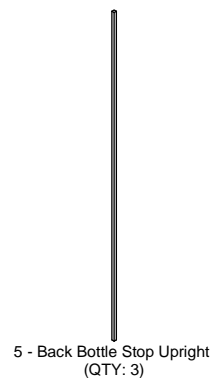
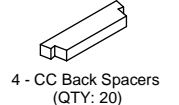
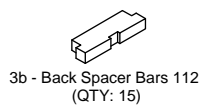
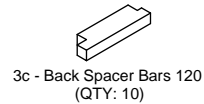
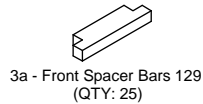
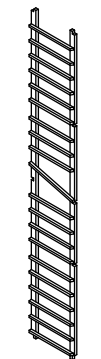
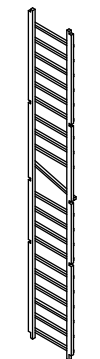

STEP 1

SECTION 1: Left & Right

Assembling the left and right columns, SECTION 1. Instead of starting from the back, the front will be done first. Place the ladders so the back is on the floor, on flat, soft surface, so not to damage the racks. Space the ladders accordingly. Place the front spacer bars (3a) according to the ladder notches.

(Note: Ensure proper placement of ladders, and bottoms are all in same direction.)

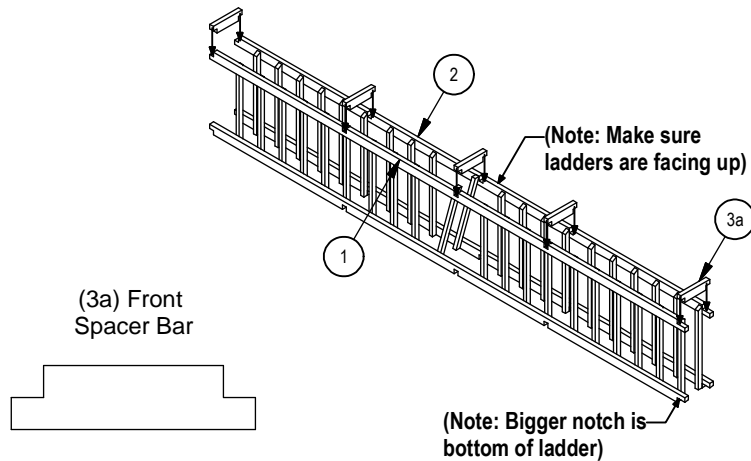

STEP 2

Starting from the bottom of the rack, firmly apply pressure to lock in the joints. Then apply two nails with a nail-gun, to each joint. Remember to firmly lock each joint, as you work your way up.

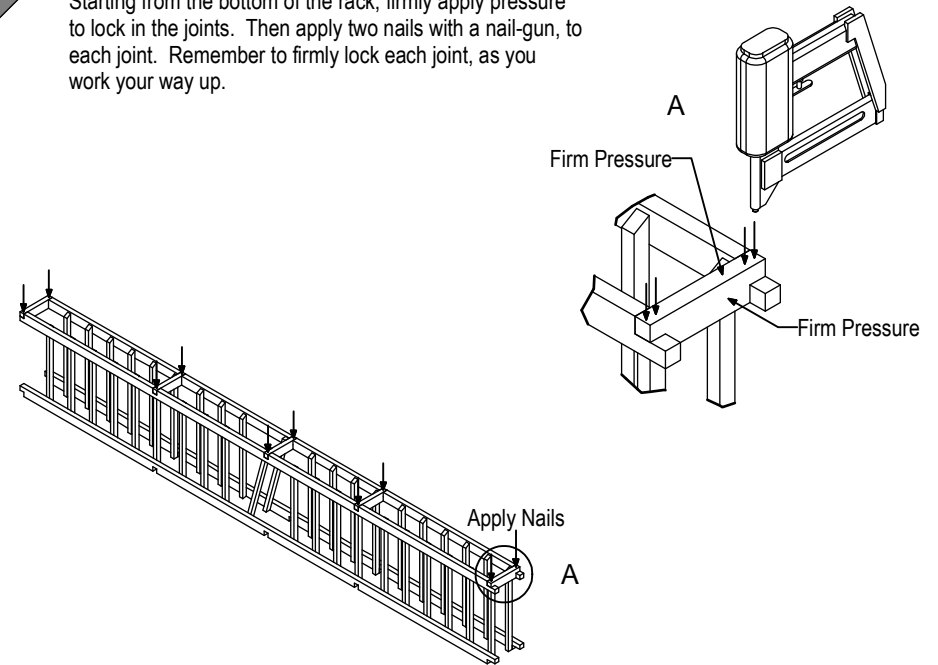

STEP 3

Turn the racks over. Front facing the floor, and back face up. Lay the racks side-by-side. For the left and right columns, back spacer bars (3c) have to be placed in specific directions. For the left column, make sure the shorter spacer bar notch is on the left, and the longer notch is flush to the right. For the right column, make sure the shorter spacer bar notch is on the right, and the longer notch is flush to the left.

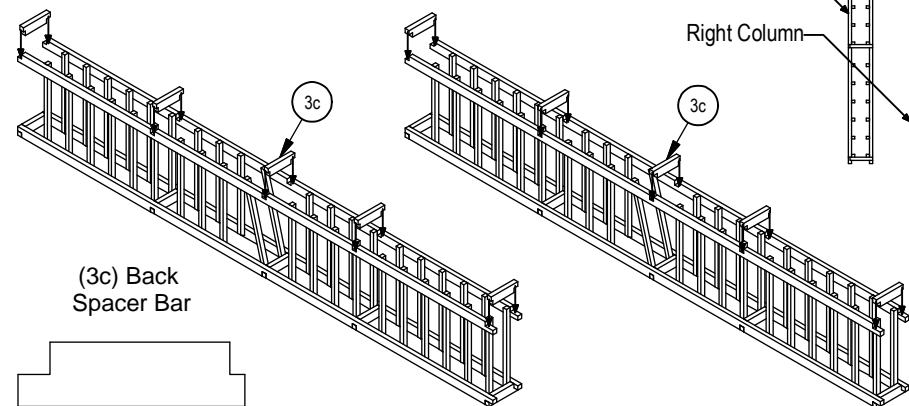
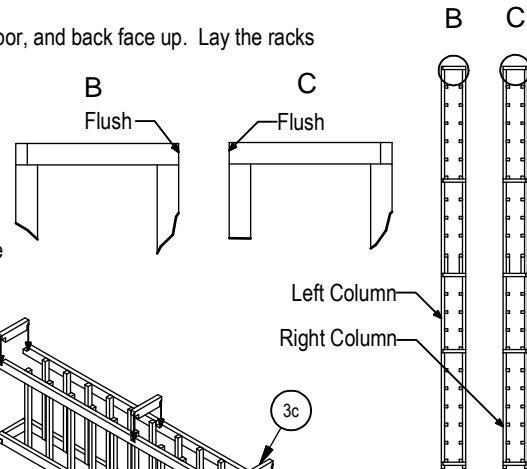

STEP 4

Once spacer bars are properly placed, start from the top of the rack. Firmly apply pressure to lock in the joint. Then apply two nails with a nail-gun, to each joint. Remember to firmly lock in each joint.

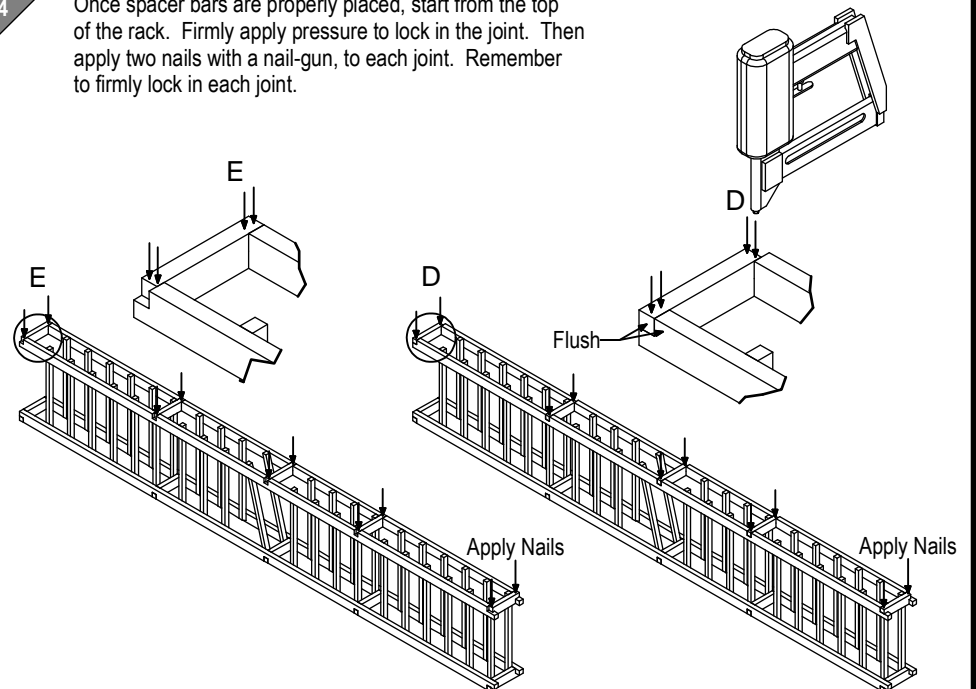

STEP
5

While the backs of the left and right columns are still facing up, screw the angled brackets to the back spacer bars as shown. Top, middle, and bottom.

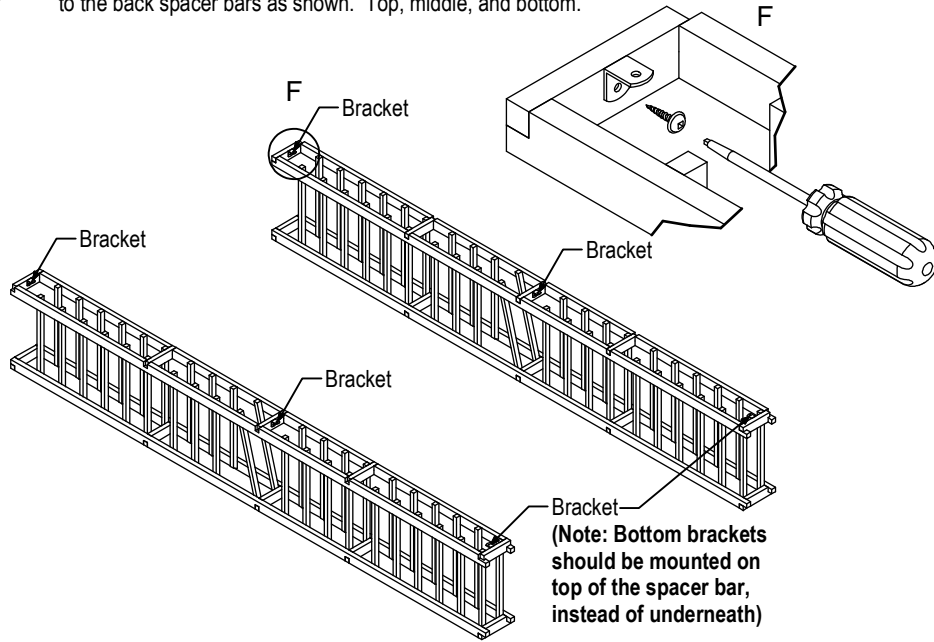

STEP
6

SECTION 2: Middles

SECTION 2, three individual columns, these will be the middle columns. Place the ladders so the front is facing up, on flat, soft surface, so not to damage back of racks. Space the ladders accordingly.
(Note: Ensure proper placement of ladders, and bottoms are all in same direction.)

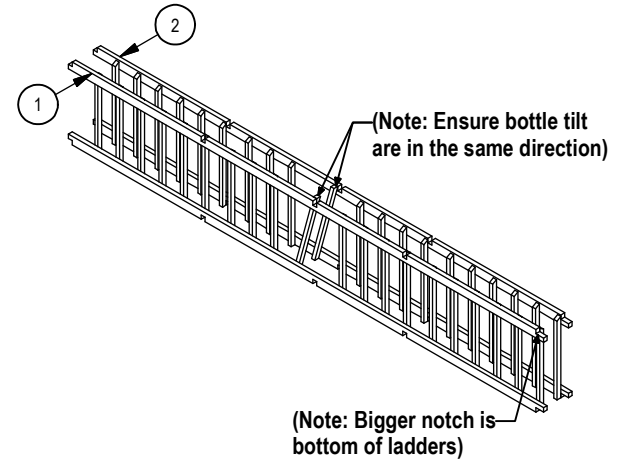

STEP
7

From the bottom and working your way up, place the front spacer bars (3a) according to the ladder notches. Make sure to carefully interlock the spacer bars to the ladders.

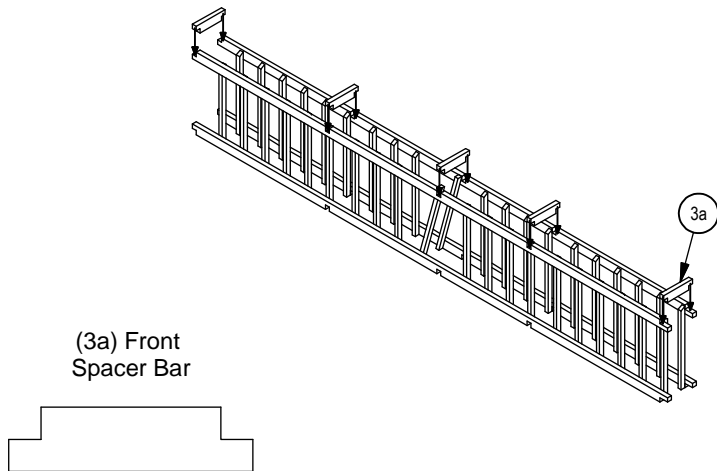

STEP
8

Once spacer bars are properly placed. Start from the bottom of the rack. Firmly apply pressure to lock in the joint. Then apply two nails with a nail-gun, to each joint. Remember to firmly lock in each joint.

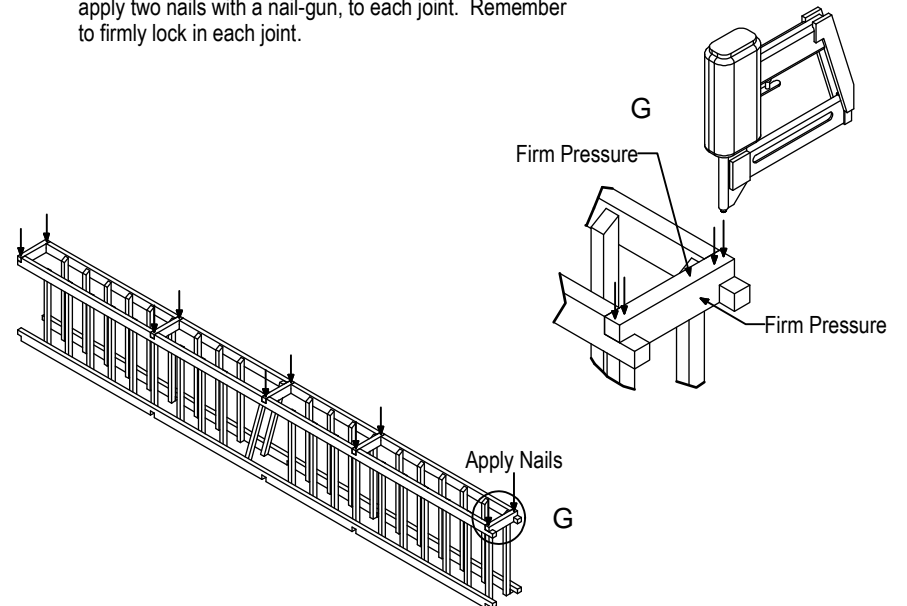

STEP
9

With the help of another person, turn the rack so the front is on the floor, and the back is facing up. Starting from bottom and work your way up, place the back spacer bars (3b) according to the ladder notches. Make sure to carefully interlock the spacer bars to the ladders.

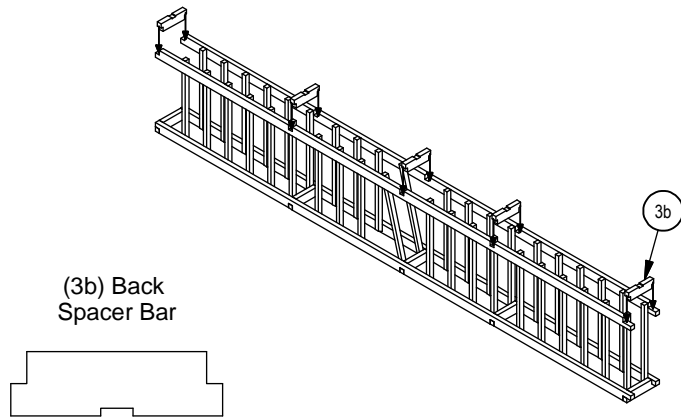

STEP
10

From the front and bottom of the rack, firmly apply pressure to lock in the joints. Then apply two nails with a nail-gun to each joint. Remember to firmly lock each joint.

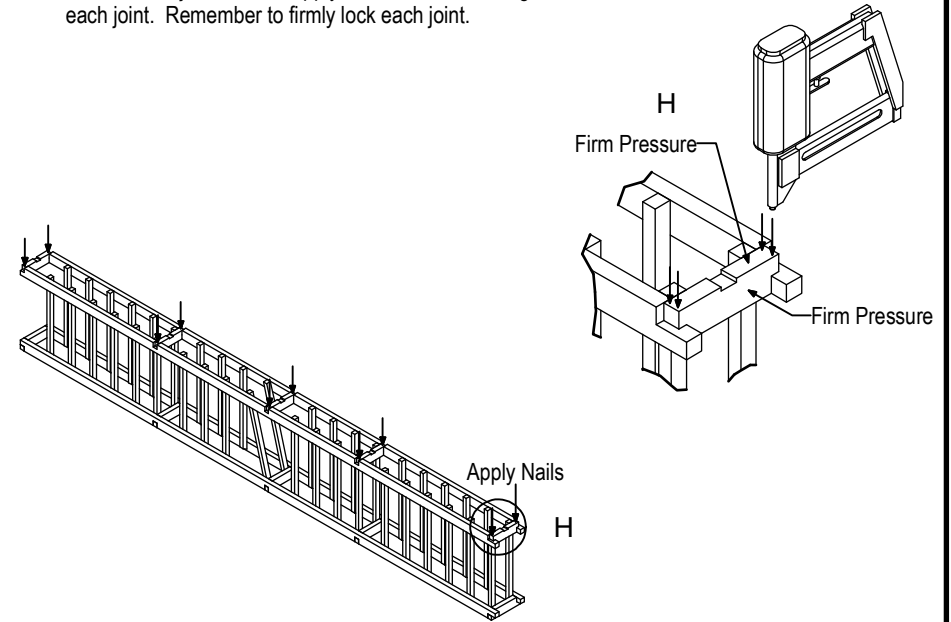

STEP
11

While the three middle columns are still laid down, apply the back bottle stop upright (5). Place the back bottle stop upright into the back spacer bar notches as shown.

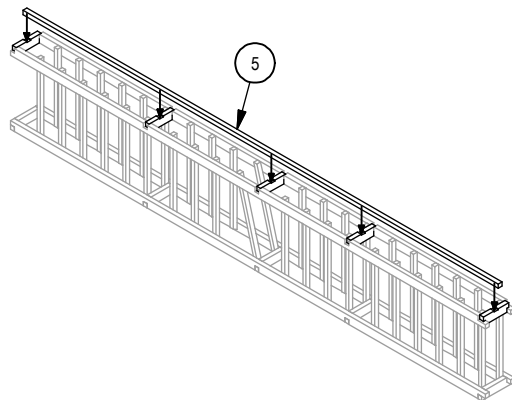

STEP
12

Flush the back bottle stop upright to the bottom of the rack. Push down and hold firm. Apply two nails with a nail-gun at each joint.

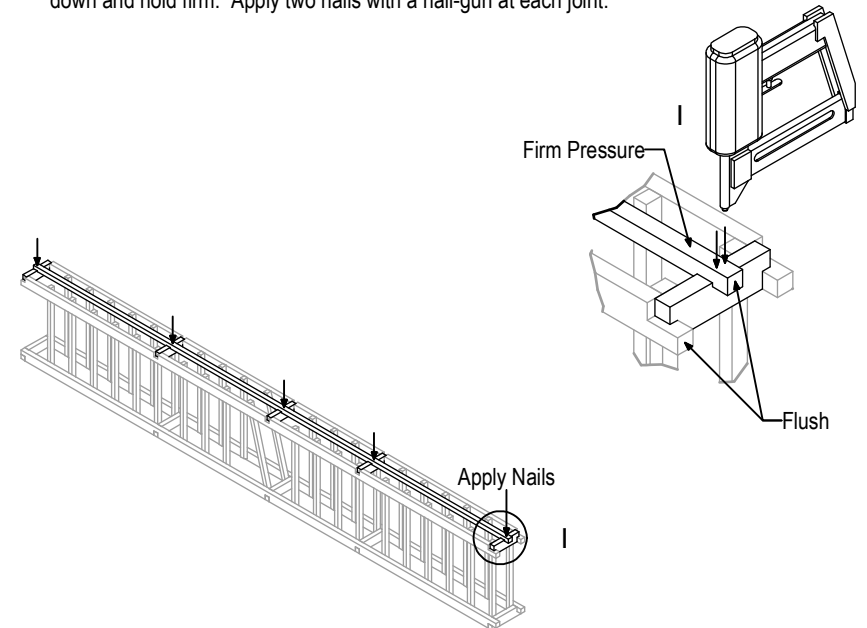

STEP
13

SECTION 3: Complete

Stand the racks up. Make sure bottoms are on the floor, left column on the left, right column on the right, and left-over columns are in the middle. Make sure the left and right column form a 90 degree, as shown. Place the front edge together, and space the back evenly. **(Note: Ensure all angle bottle displays are facing front)**

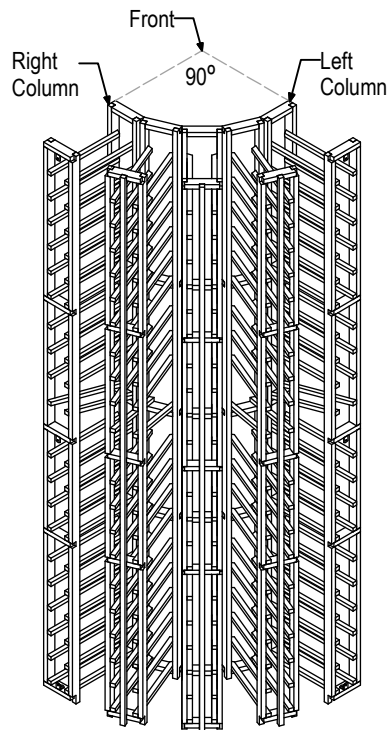

STEP
14

Starting at the middle height, place the CC back spacers (4) between the columns as shown.

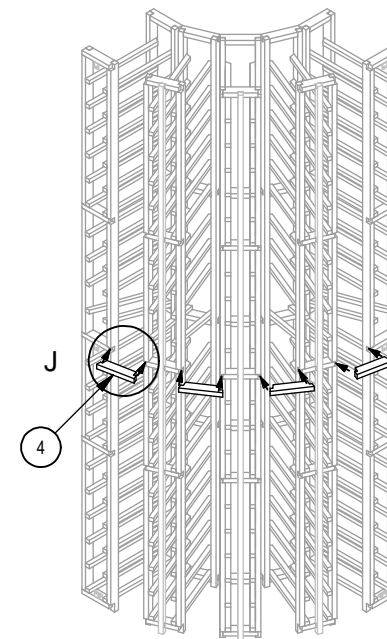
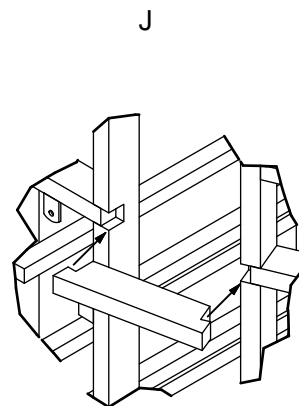

STEP
15

Firmly hold the spacer in place, and apply two nails at each end of the CC back spacer. Do the same to the rest.

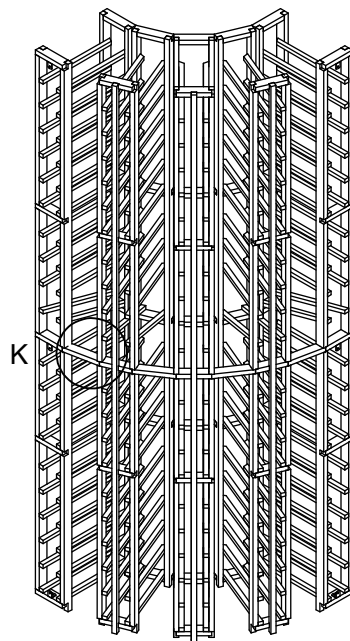
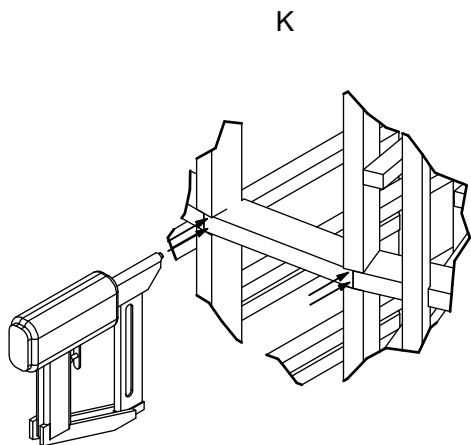

STEP
16

Once the middle height spacers are done, work your way down the racks, one level at a time.

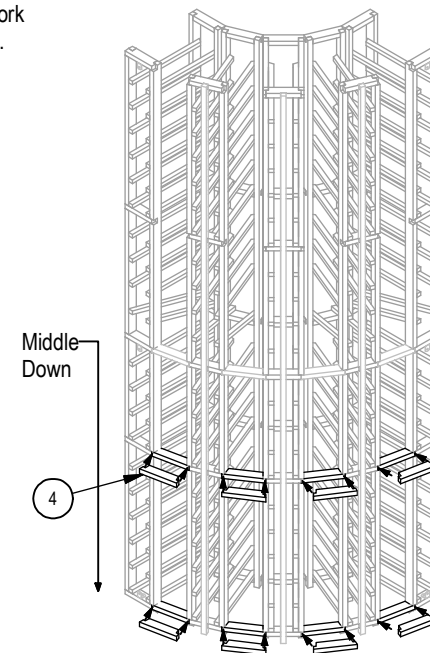

STEP
17

When the lower portion is complete, work your way up the racks from center, one level at a time.

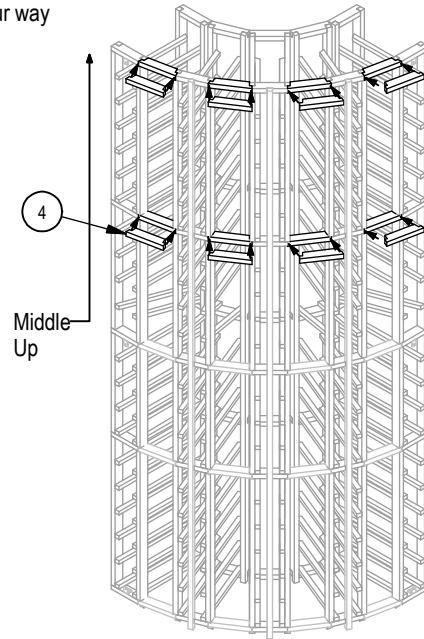

STEP
18

Nailing the front edge joints. Starting from the left edge joint, align the edges, hold firmly and apply two nails on each side of the racks, as shown. Nail as close as you can to the spacer bar. Continue down the rack, apply nails at each spacer bar level.

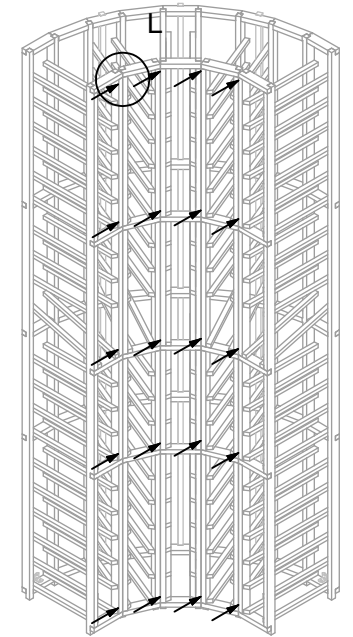
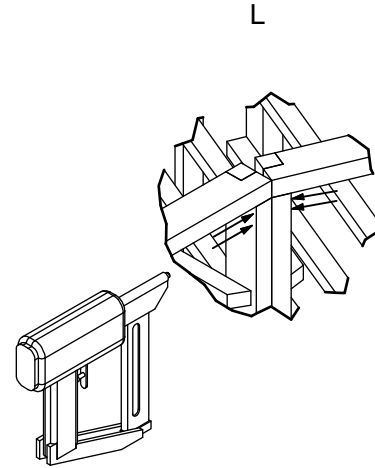

STEP
19

Applying tilt stop. Start from left side of racking, place the Tilt Stop Edge as show. Flush to the side and bottom. Hold firmly in place and apply two nails on each edge. Apply the same way for the rest of tilt stops.

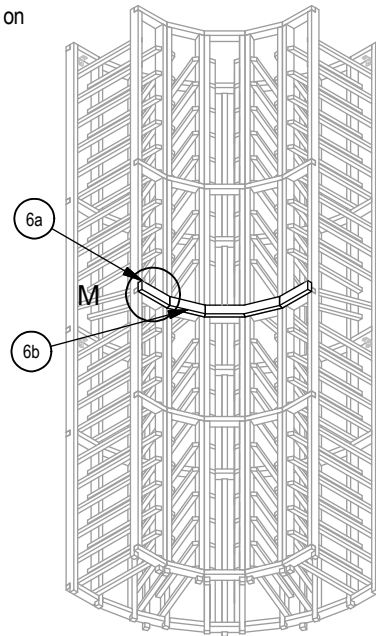
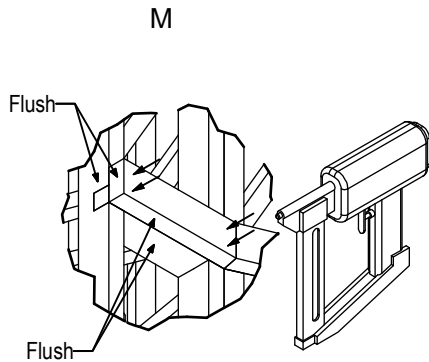

STEP
20

Optional, finish the curved corner rack by applying the base and crown mould.

