

# ELITE KIT RACK ASSEMBLY INSTRUCTION

Thank you for purchasing Elite Kit Rack by Genuine Cellars. The following instructions will help you assemble the 750ml CASCADE LEFT. The same procedure can be applied to the following kits shown.

Please study the instructions carefully prior to starting the assembly.

750ml CASCADE LEFT

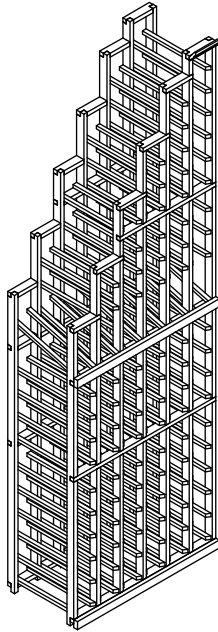

750ml CASCADE RIGHT

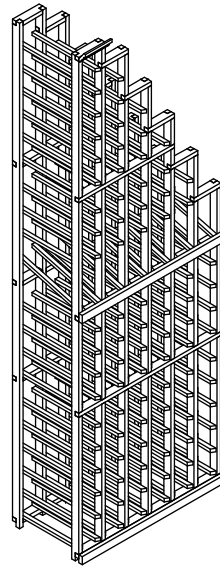

## HARDWARE

The following hardware is included in all kits:  
(QUANTITY WILL VARY, DEPENDING ON KIT.)

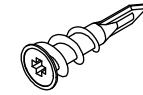

Drywall Anchors  
(QTY: 5)



#8 Robertson Screws  
(Square Head)  
(QTY: 5)

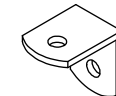

Angled Brackets  
(QTY: 5)



#6 Robertson Screws  
(Square Head)  
(QTY: 5)

## TOOLS REQUIRED

The following tools are required (NOT INCLUDED):

### IMPORTANT!

Always follow the manufacturer's instructions on how to use the nail gun, to prevent injury. Genuine Cellars is not liable for any injury incurred while assembling the kit.

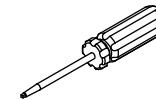

Robertson  
Screwdrivers #6 & #8  
(Square Head)

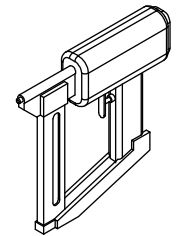

**We Recommend A  
21 Gauge Nail Gun**  
(Use 21 gauge brand nails,  
with appropriate air compressor  
or electric nailer set to 80psi,  
to prevent splitting)

## COMPONENTS

The following components are included in the 750ml CASCADE LEFT.

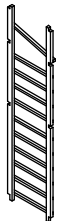

1 - Left  
Ladder 1257  
(QTY: 1)

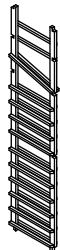

2a - Middle  
Ladder 1449  
(QTY: 1)

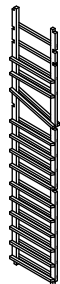

2b - Middle  
Ladder 1661  
(QTY: 1)

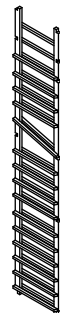

2c - Middle  
Ladder 1853  
(QTY: 1)



2d - Middle  
Ladder 2045  
(QTY: 1)



2e - Middle  
Ladder 2130  
(QTY: 1)



3 - Right  
Ladder 2130  
(QTY: 1)

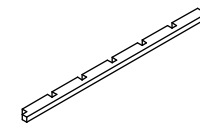

4a - Front Spacer Bars 689  
(QTY: 3)

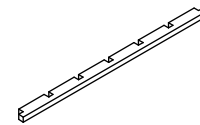

4b - Back Spacer Bars 689  
(QTY: 3)



6a - Front Spacer Bars 129  
(QTY: 6)

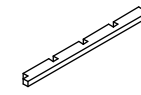

5a - Front Spacer Bars 465  
(QTY: 1)

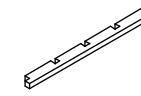

5b - Back Spacer Bars 465  
(QTY: 1)



6b - Back Spacer Bars 129  
(QTY: 6)

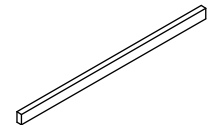

7 - Tilt Stop 689  
(QTY: 1)

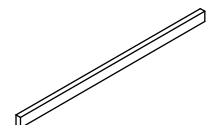

9 - Base Mould 689  
(QTY: 1)



8 - Crown Mould 129  
(QTY: 1)

**STEP 1**

Starting from the back of the racks. Place the ladders on flat, soft surface, so not to damage front of racks. Space the ladders accordingly. **(Note: Ensure proper placement of ladders, and bottoms are all in same direction as shown.)**

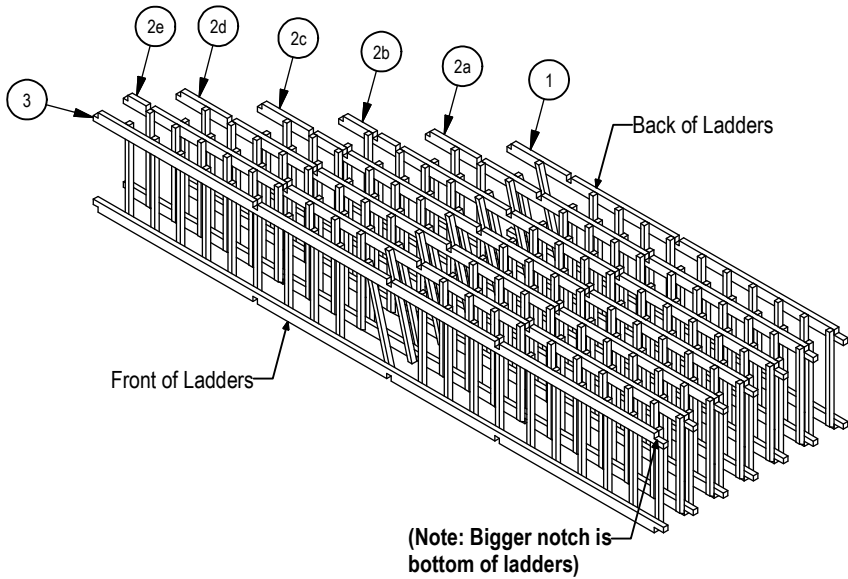

**STEP 2**

From the bottom and working your way up, place the back spacer bars (4b)(5b)(6b) according to the ladder notches. Make sure to carefully interlock the spacer bars to the ladders.

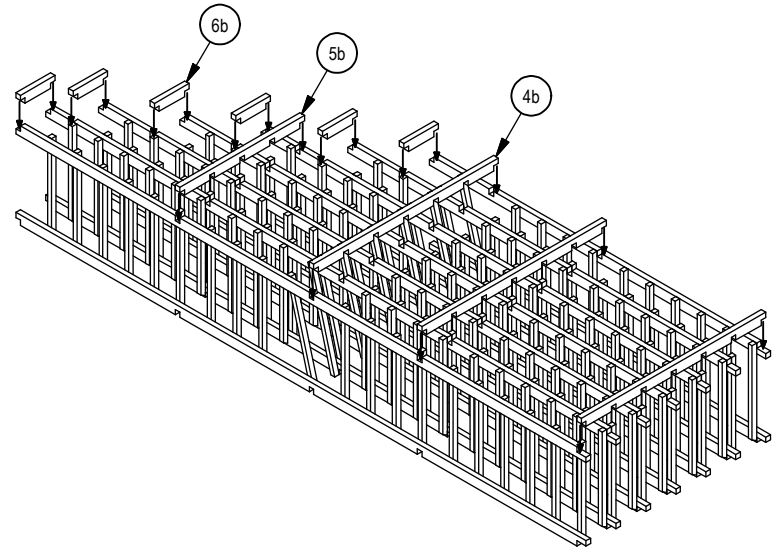

**STEP 3**

Once spacer bars are properly placed. Start from the bottom of the rack, firmly apply pressure to lock in the joint. Then apply two nails with a nail-gun, to each joint. Remember to firmly lock in each joint.

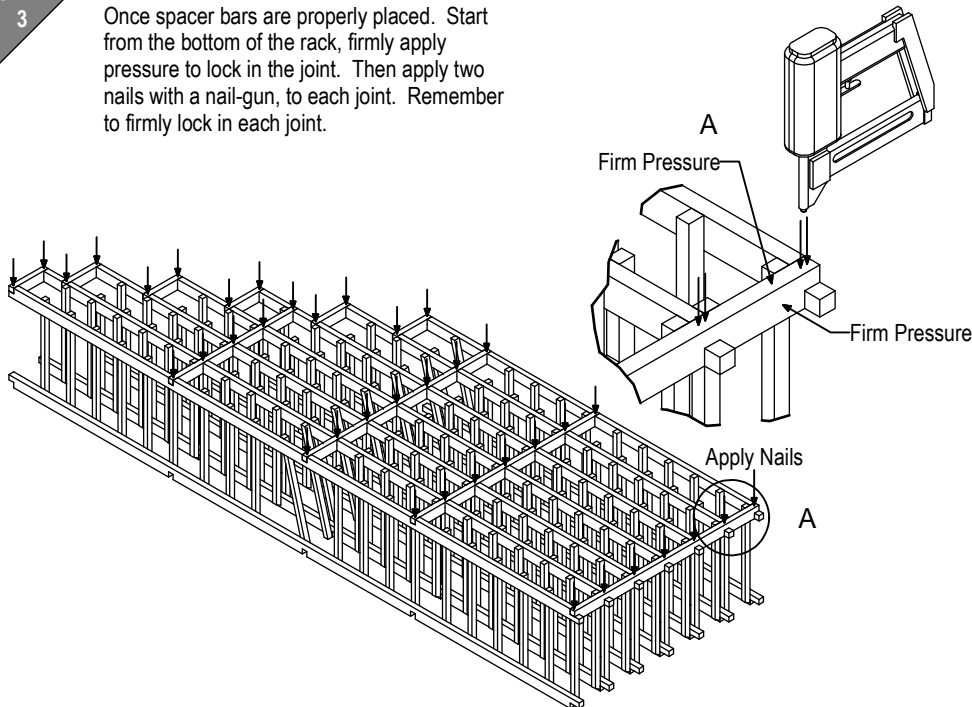

**STEP 4**

While backs are still facing up, screw the angled brackets to the back spacer bars as shown.

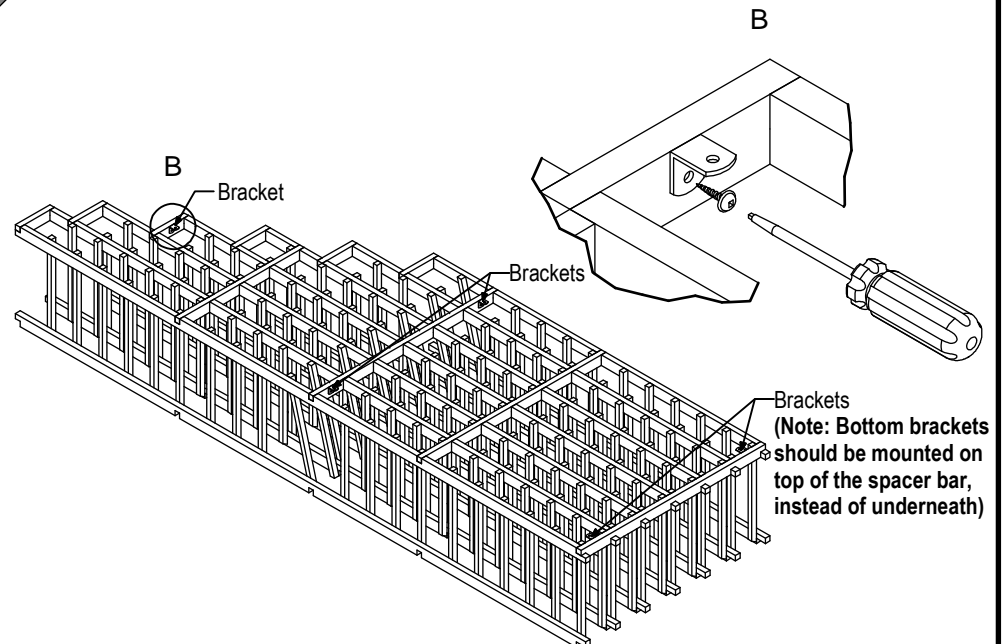

**STEP**  
**5**

With the help of another person, turn the rack so the back is on the floor, and the front is facing up. Starting from bottom and work your way up, place the front spacer bars (4a)(5a)(6a) according to the ladder notches. Make sure to carefully interlock the spacer bars to the ladders.

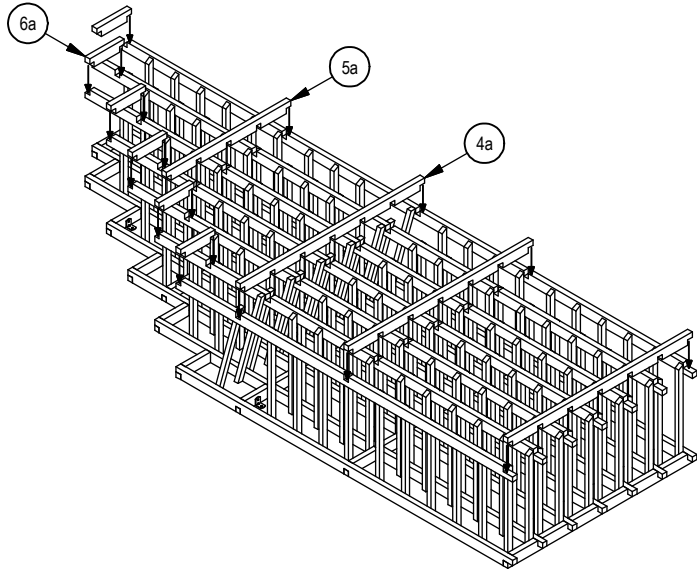

**STEP**  
**6**

From the front and bottom of the rack, firmly apply pressure to lock in the joint. Then apply two nails with a nail-gun, to each joint. Remember to firmly lock in each joint.

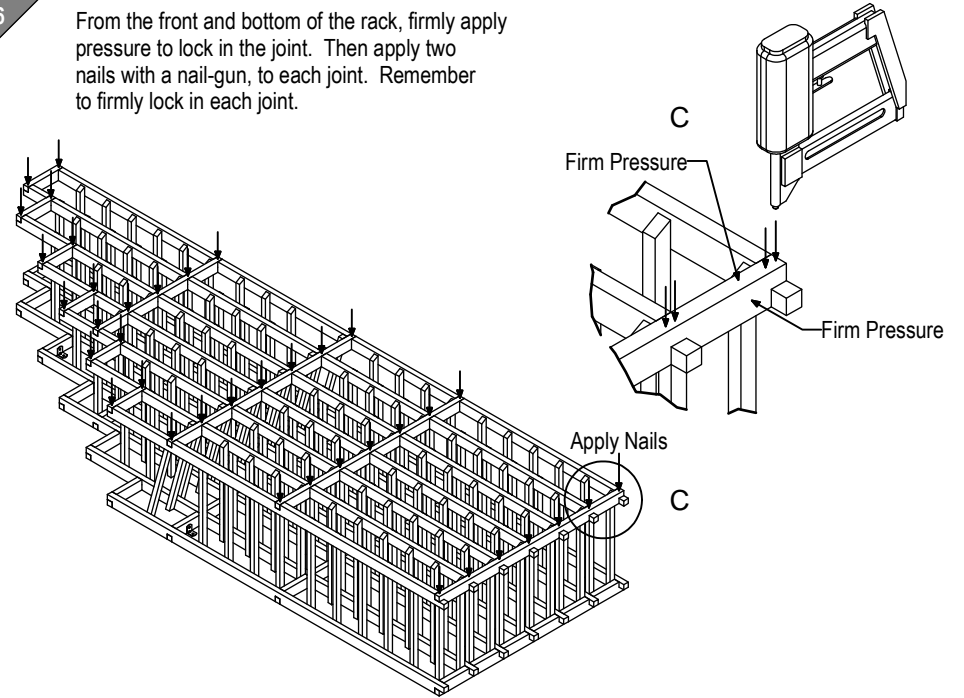

**STEP**  
**7**

Applying the tilt stop, flush the tilt stop (7) to the bottom of the front, middle spacer bar. Also, make sure to flush the tilt stop to the edge of the right or left ladder. Hold firm and nail twice on each ladder.

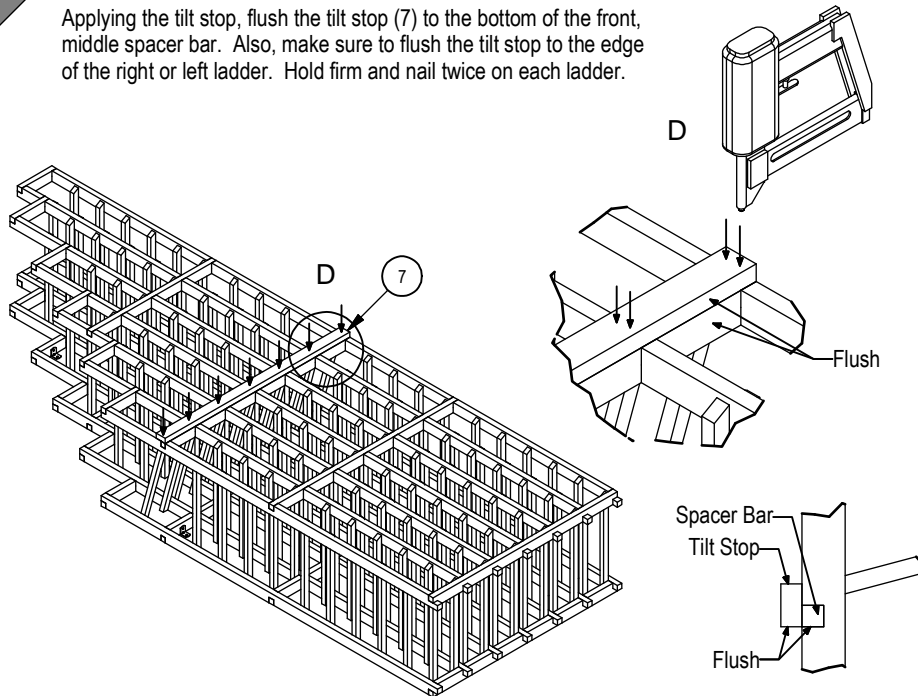

**STEP**  
**8**

Optional, finish the cascade rack by applying the base and crown mould.

